

Installation Manual

For outdoor installation
In-ground light

Model: LLG-7166LUB / LLG-7166YUB

- For outdoor installation (rainproof, moisture-proof)
- For installation on the ground (Recessed type)
- Bolt mounting method
- With overheat protection function
- LED unit is non-replaceable
- Non-Dimmable

Name of parts

*The diagram below is a simplified illustration.

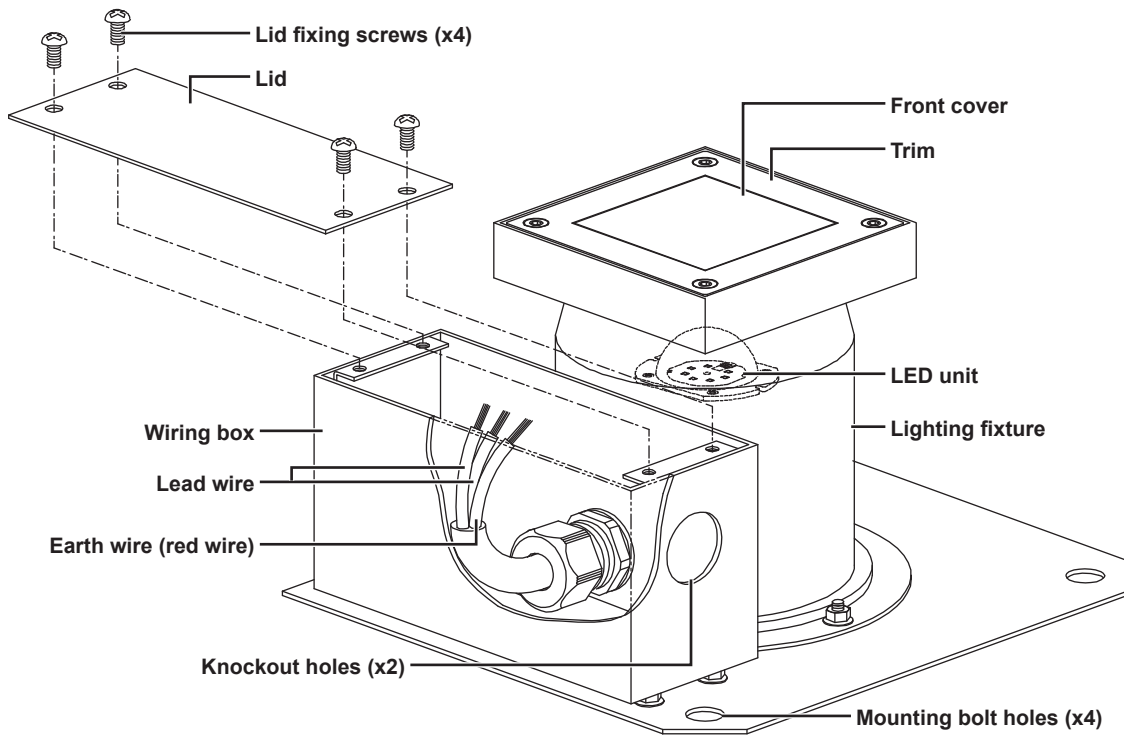

Mounting dimensions

Unit: mm

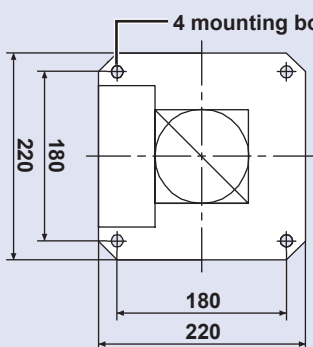

Required burying depth

Unit: mm

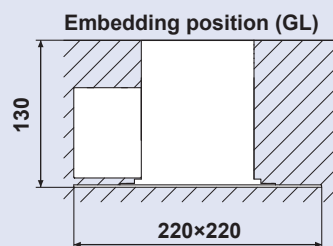

Sold separately



Electrical insulating resin pack
Scotchcast WS-0
(Manufactured by 3M)

Precautions before Installation

- Use a protective conduit or similar method to protect the power supply cable up to the knockout holes of the wiring box.
- *The power supply cable, cable protective conduit, bolts, nuts, washers and spring washers are not included with the fixture. Please prepare these separately.
- Make sure to provide drainage.
- Install the fixture in a location with a solid substrate and good drainage.

Warning

- Do not install in the following locations. This may cause insulation failure or malfunction.**
- Uneven ground
 - Locations with soft subsoil
 - Locations at risk of flooding
 - Locations where the fixture may be covered by vegetation
 - Locations subject to vehicle loads, etc.

Do not loosen the screws or remove the trim.
This may compromise the waterproof function and cause insulation failure or electrical leakage.

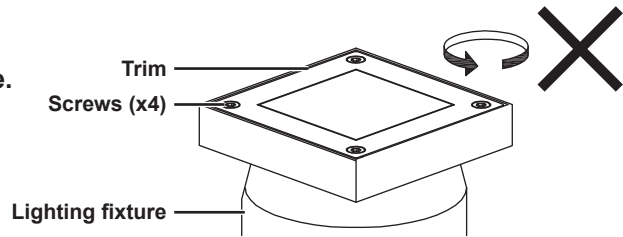

Installation Procedure

1 Check the mounting surface.

*Bolts are not included with the fixture. Please prepare M10 bolts separately.

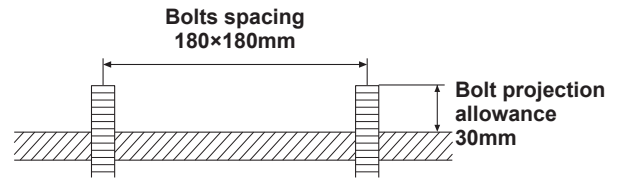
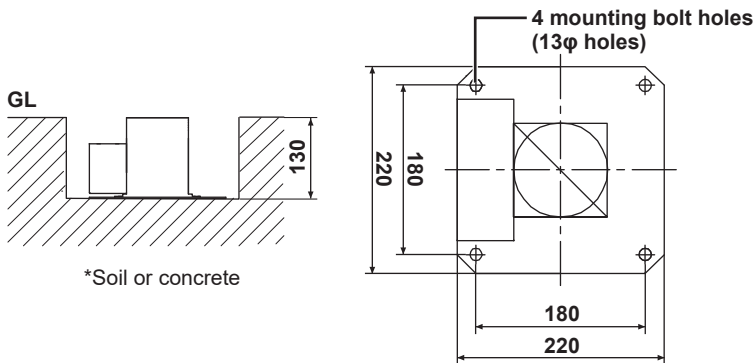

- Check the bolts spacing and the bolt projection allowance.

2 Install the lighting fixture.

*Washers, spring washers and nuts are not included with the fixture. Please prepare M10 washers, spring washers and nuts separately to match the bolts.

*Provide sufficient drainage to prevent water accumulation.

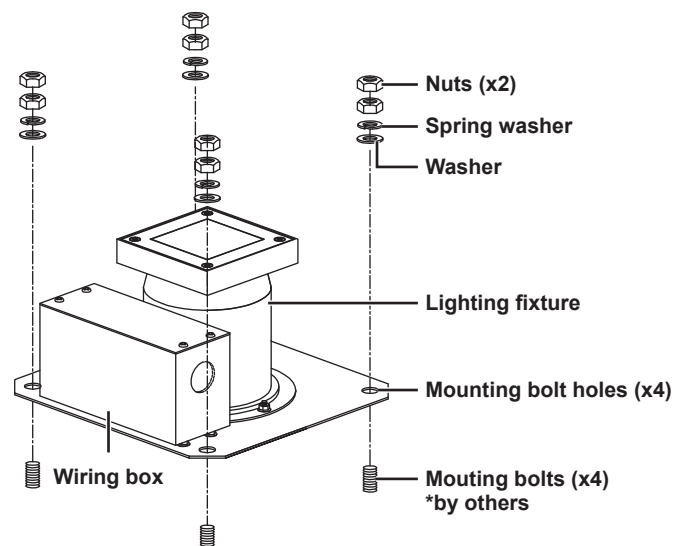

3 Remove the lid.

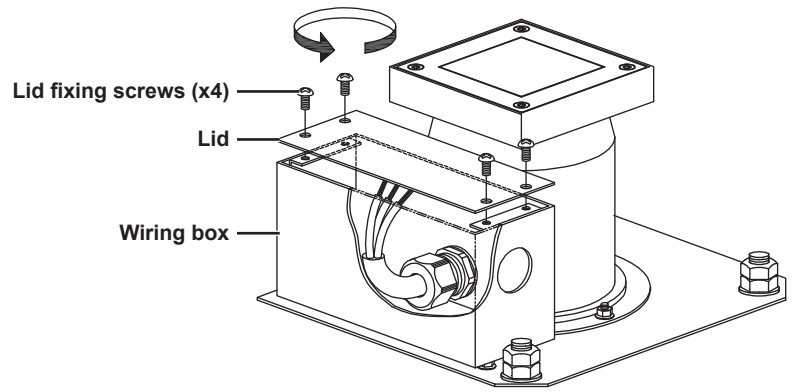

4 Connect the power supply cable. (Be sure to turn off the power before starting work.)

*When not performing through-wiring, use closed end connectors (small); when performing through-wiring, use closed end connectors (large).

*The cable protective conduit and closed end connectors are not included with the fixture. Please prepare these separately.

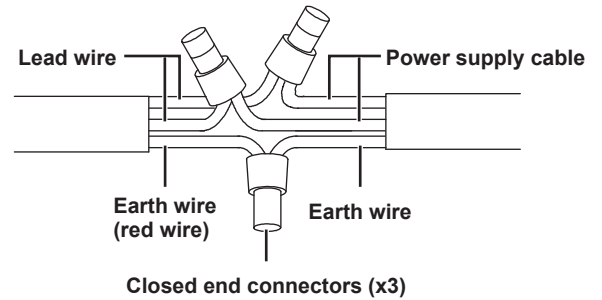

5 Apply waterproofing to the connection wiring part.

*Make sure to waterproof the connection section using a separately sold electrical insulating resin pack (3M Scotchcast WS-0) or equivalent.

*Make sure to insert the connection section into the spacer net until the tape position on the outer sheath of the lead wire is hidden.

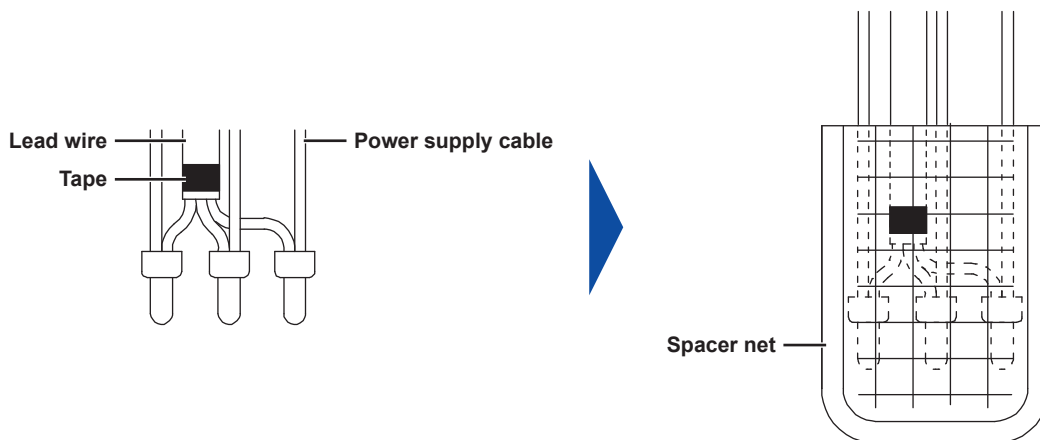

*The resin will harden in about 2 hours. Be careful not to burn yourself as the resin becomes hot during hardening.

6 Attach the lid.

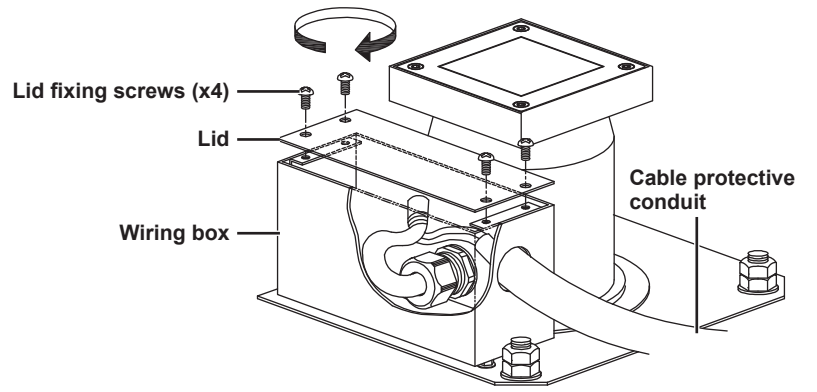

7 Embed the fixture.

