

Installation Manual

For outdoor installation
In-ground light

Model: LLG-7133LUM / LLG-7133LUW / LLG-7133YUM / LLG-7133YUW
LLG-7134LUM / LLG-7134LUW / LLG-7134YUM / LLG-7134YUW

- For outdoor installation (rainproof, moisture-proof)
- For installation on the ground (Recessed type)
- Bolt mounting method
- With overheat protection function
- LED unit is non-replaceable
- Non-Dimmable

Name of parts

*The diagram below is a simplified illustration.

Model No. LLG-7133LUM / LLG-7133LUW / LLG-7133YUM / LLG-7133YUW

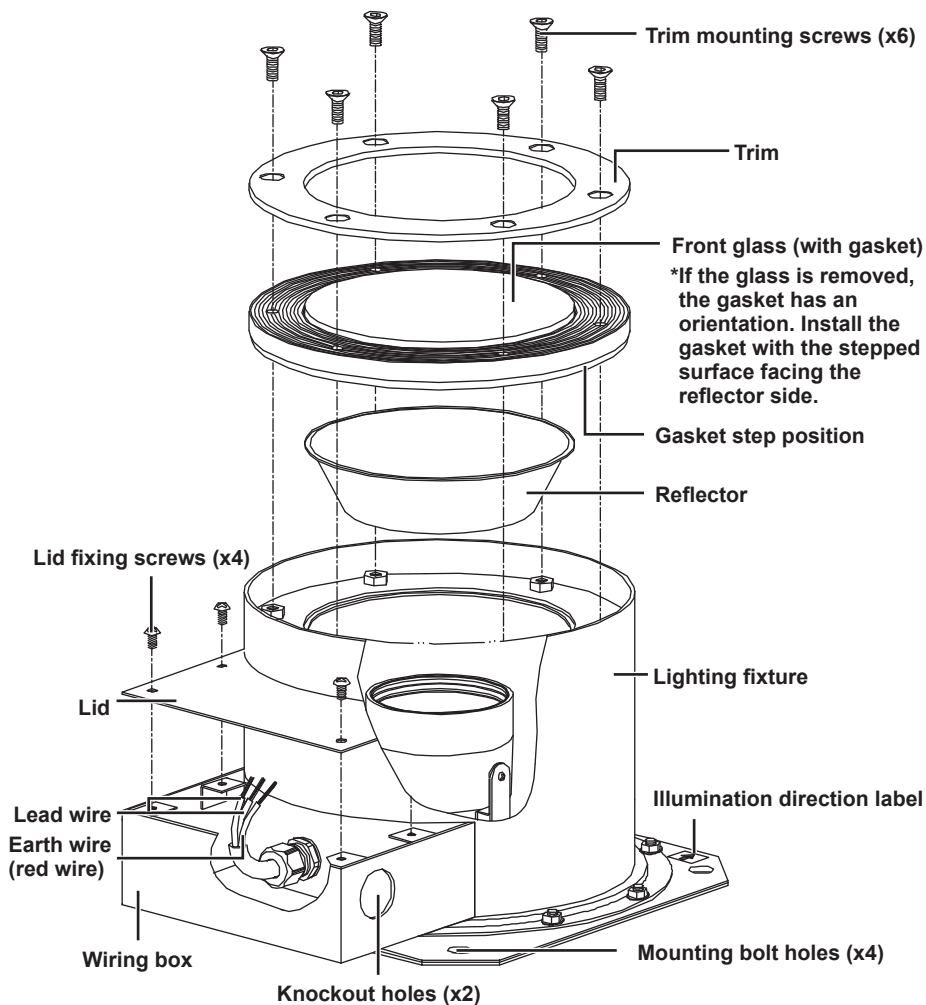

Enclosed parts

- Hexagonal wrench (nominal size: 4)
- Desiccant (in bag)

Sold separately

- Electrical insulating resin pack
Scotchcast WS-0
(Manufactured by 3M)

Required burying depth

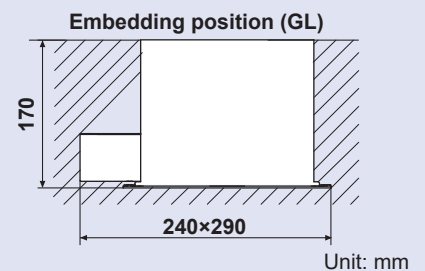

Mounting dimensions

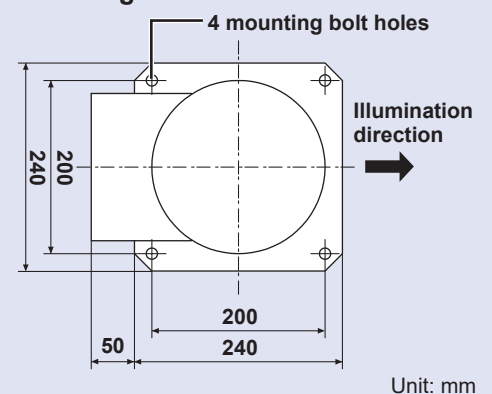

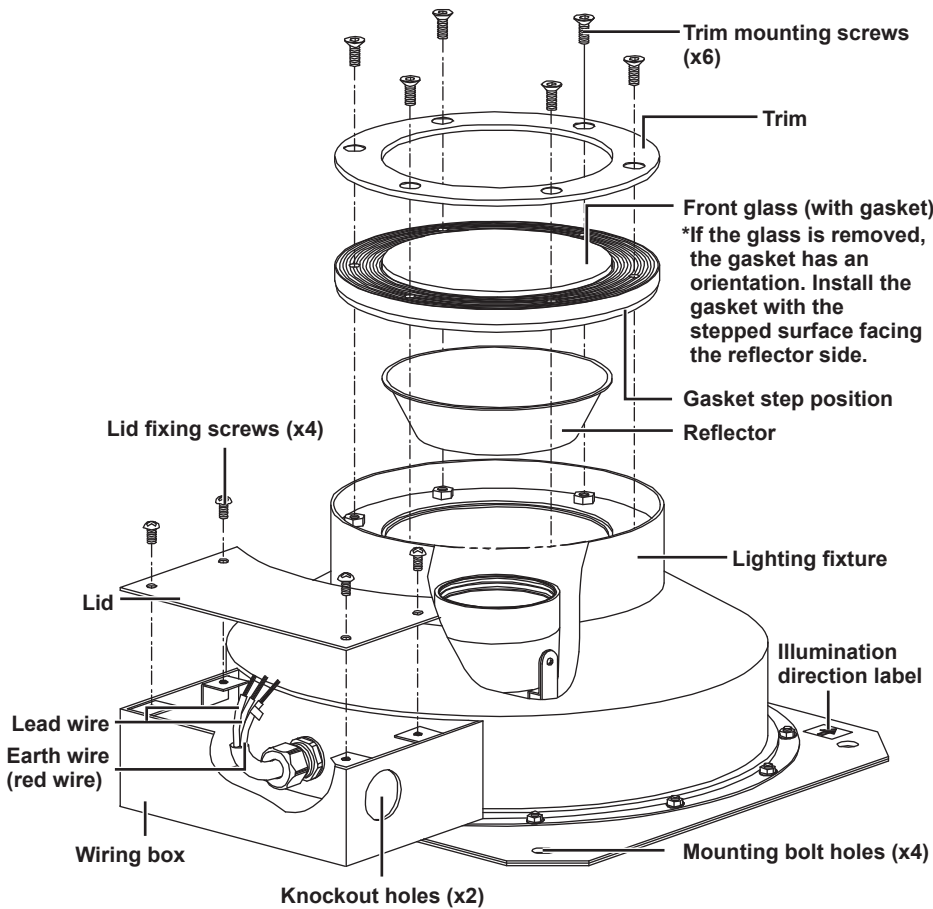

Enclosed parts

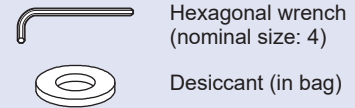

Sold separately

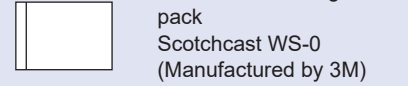

Required burying depth

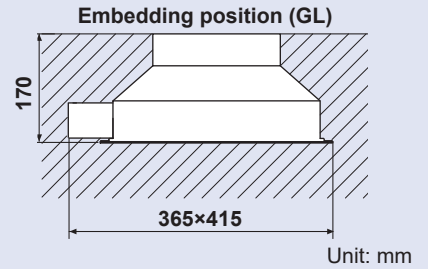

Mounting dimensions

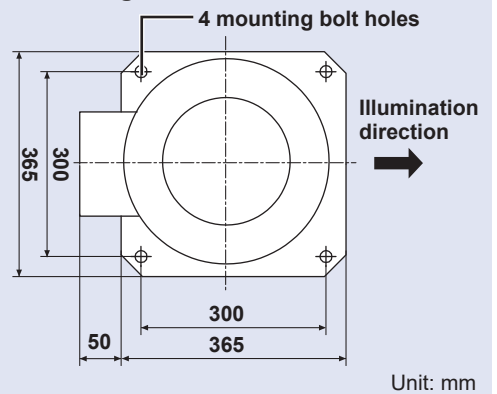

Precautions before Installation

- Use a protective conduit or similar method to protect the power supply cable up to the knockout holes of the wiring box.
- *The power supply cable, cable protective conduit, bolts, nuts, washers and spring washers are not included with the fixture. Please prepare these separately.
- Make sure to provide drainage.
- Install the fixture in a location with a solid substrate and good drainage.

Warning

- Do not install in the following locations. This may cause insulation failure or malfunction.
- Uneven ground
 - Locations with soft subsoil
 - Locations at risk of flooding
 - Locations where the fixture may be covered by vegetation
 - Locations subject to vehicle loads, etc.

Installation Procedure

1 Check the mounting surface.

- Check the illumination direction and install the bolts.
- *Bolts are not included with the fixture. Please prepare M10 bolts separately.

< LLG-7133 >

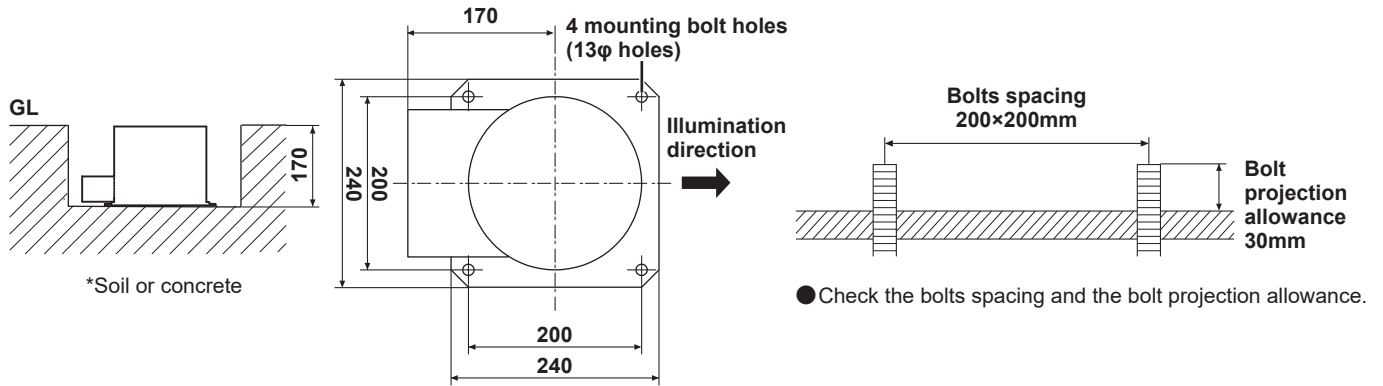

< LLG-7134 >

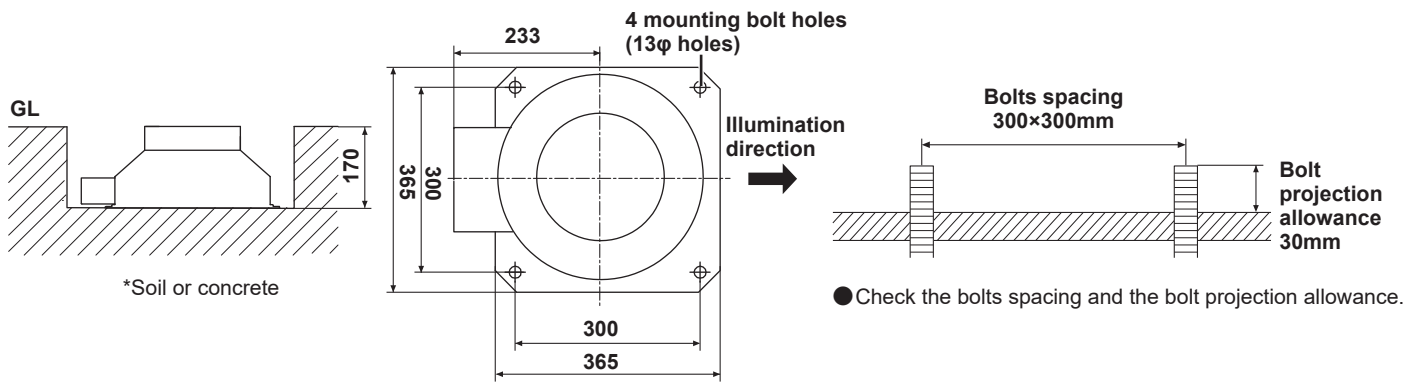

2 Install the lighting fixture.

- Install the fixture with the arrow on the illumination direction label pointing in the illumination direction.
- *Washers, spring washers and nuts are not included with the fixture. Please prepare M10 washers, spring washers and nuts separately to match the bolts.
- *Provide sufficient drainage to prevent water accumulation.

< LLG-7133 >

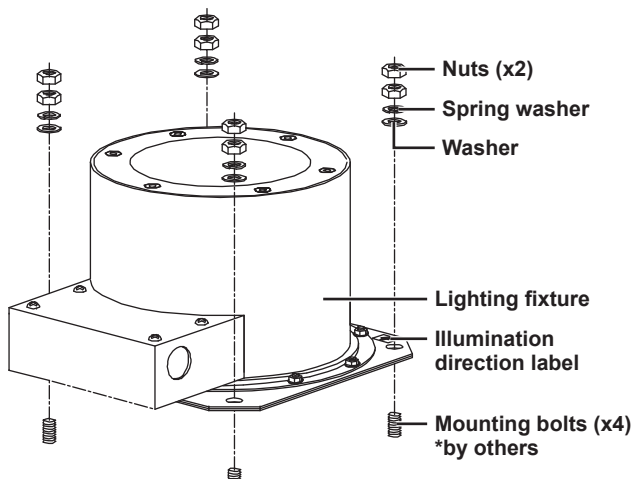

< LLG-7134 >

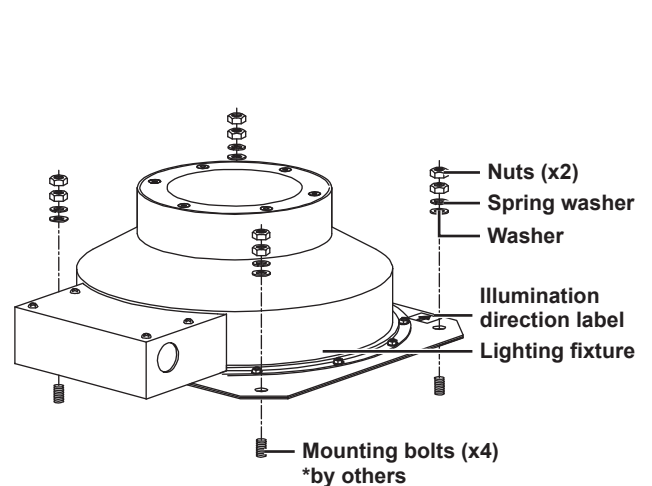

3 Remove the lid.

< LLG-7133 >

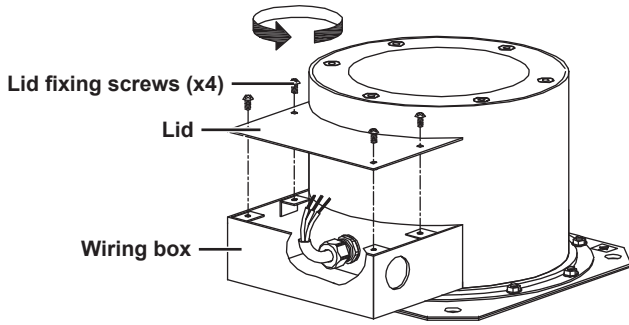

< LLG-7134 >

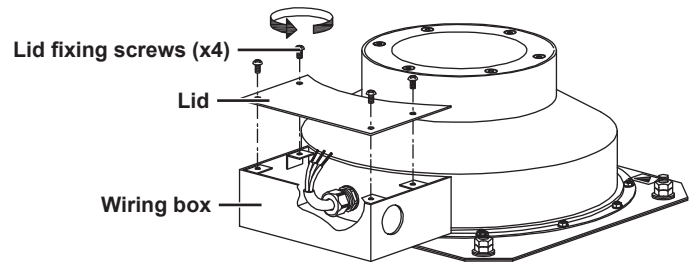

4 Connect the power supply cable. (Be sure to turn off the power before starting work.)

*When not performing through-wiring, use closed end connectors (small); when performing through-wiring, use closed end connectors (large).

*The cable protective conduit and closed end connectors are not included with the fixture. Please prepare these separately.

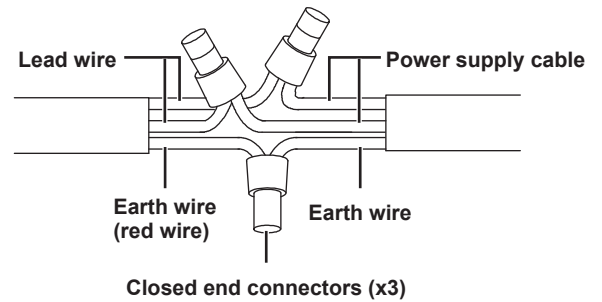

5 Apply waterproofing to the connection wiring part.

*Make sure to waterproof the connection section using a separately sold electrical insulating resin pack (3M Scotchcast WS-0) or equivalent.

*Make sure to insert the connection section into the spacer net until the tape position on the outer sheath of the lead wire is hidden.

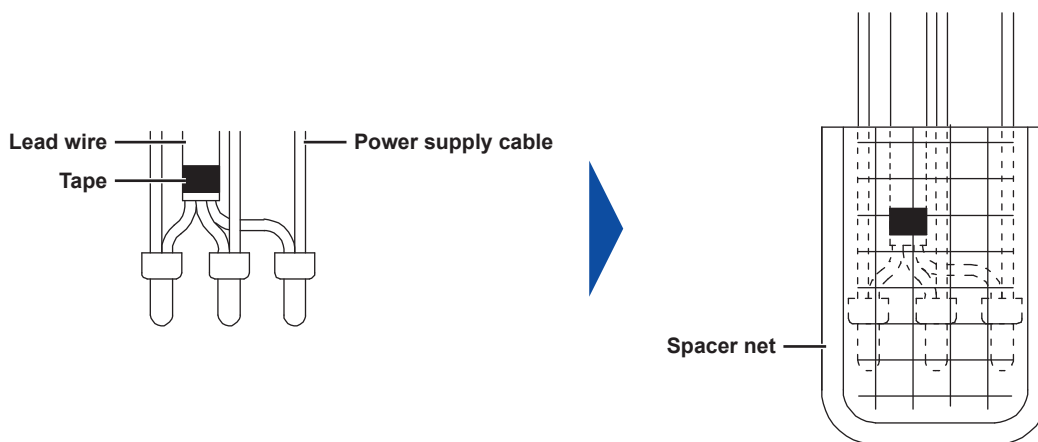

*The resin will harden in about 2 hours. Be careful not to burn yourself as the resin becomes hot during hardening.

6 Attach the lid.

- Set the lid on the wiring box, then securely tighten and fasten the lid mounting screws (x4).

< LLG-7133 >

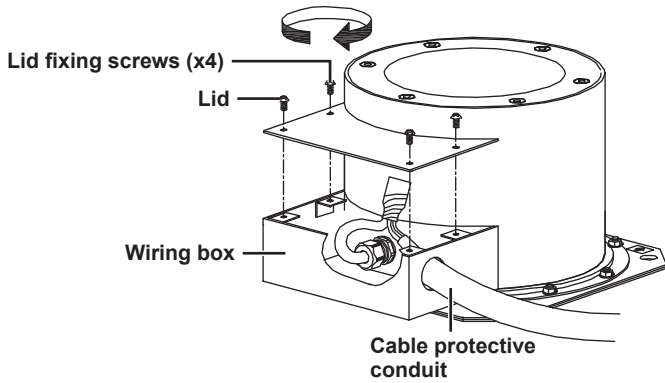

< LLG-7134 >

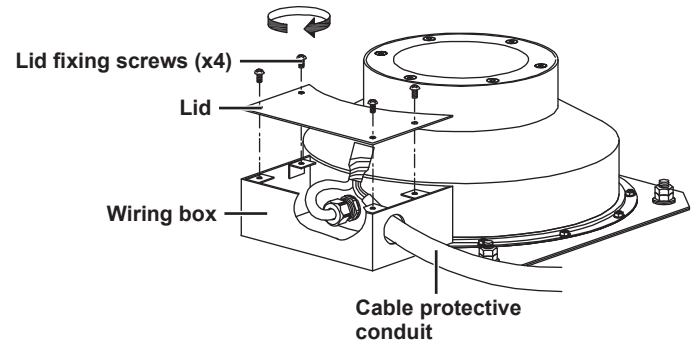

7 Remove the trim, front glass, and reflector.

- Remove the trim mounting screws (x6) with the included hexagonal wrench, then remove the trim, front glass, and reflector.
- *Do not pry open the front glass using a screwdriver, etc. The lighting fixture may deform and cause water intrusion.

< LLG-7133 >

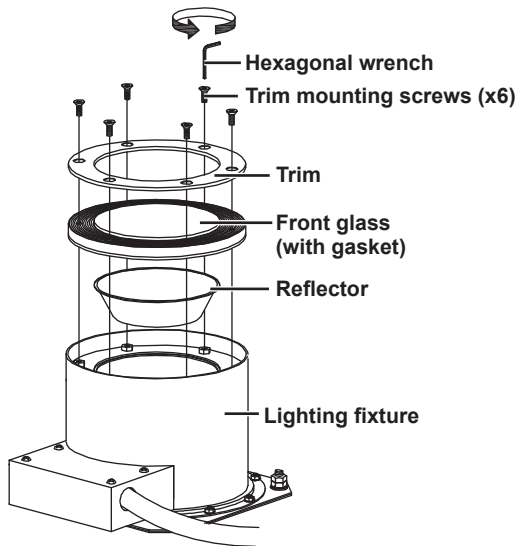

< LLG-7134 >

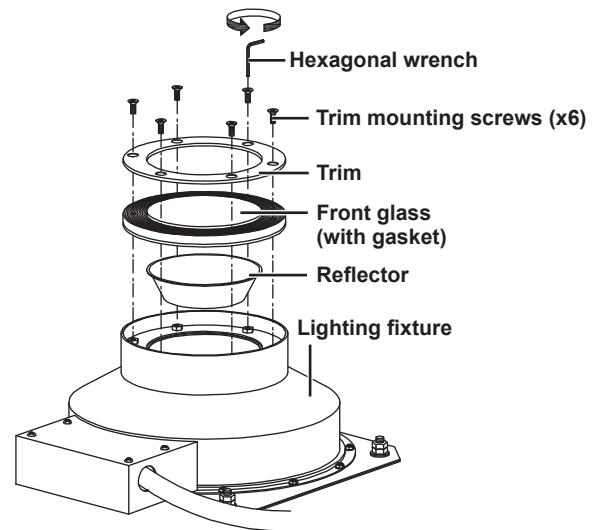

8 Insert the desiccant.

- Remove the desiccant from the bag and place it in the bottom of the lighting fixture.
- *Do not use any desiccant other than the one provided.
- *This desiccant is exclusively for this fixture. Do not use it for any other purpose.

< LLG-7133 >

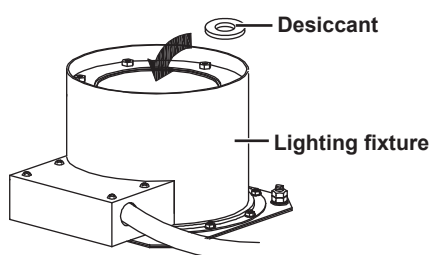

< LLG-7134 >

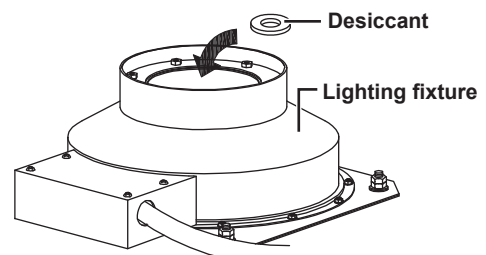

9 Adjusting the lighting fixture angle and position

< LLG-7133 >

● Range of movement

Tilt angle

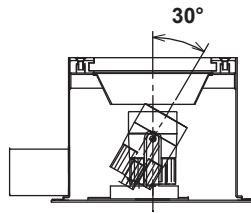

Rotation angle

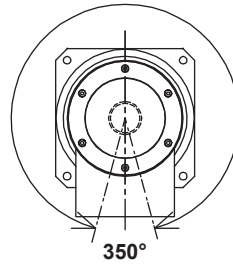

Horizontal direction

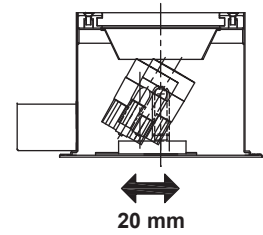

< LLG-7134 >

● Range of movement

Tilt angle

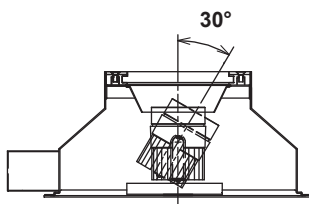

Rotation angle

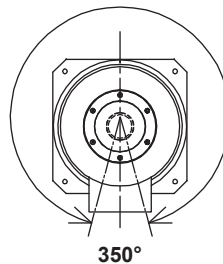

Horizontal direction

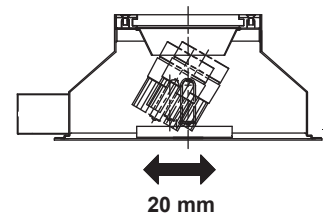

Warning

- Do not apply excessive force or move it beyond the movable range of the lighting fixture. This may cause fire, electric shock, or falling.

Caution

- The LED becomes hot during operation and immediately after turning off, so do not touch it. Touching may cause burns.
- Do not illuminate other fixtures. The heat generated during illumination may cause burning damage or failure.

10 Install the reflector, front glass, and trim.

- Set the reflector, front glass, and trim on the lighting fixture in that order.
- Securely tighten and fasten the trim mounting screws (x6) with the included hexagonal wrench.
- *Check that the gasket on the front glass has not shifted out of place.
- *Install the front glass with the stepped surface of the gasket facing the reflector side.
- *Work carefully to prevent foreign matter such as pebbles, sand, or soil from being caught between the front glass gasket and the lighting fixture and trim.
- *When tightening the trim mounting screws (x6), make sure to tighten the six screws evenly.
(Recommended tightening torque: 2.0 to 2.2 N·m)

< LLG-7133 >

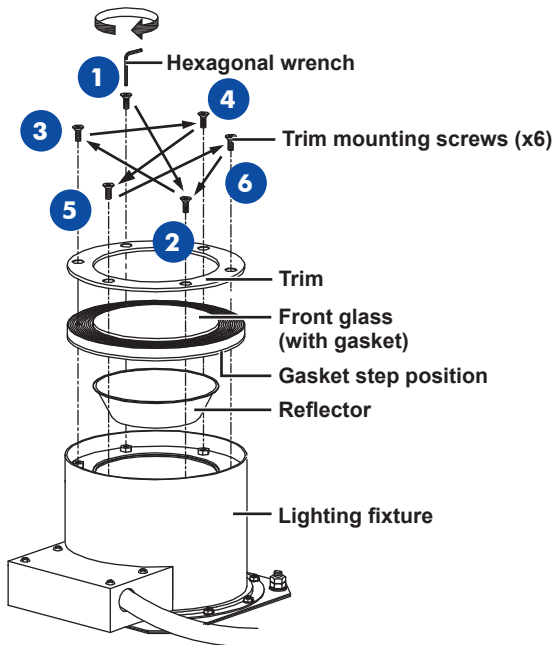

< LLG-7134 >

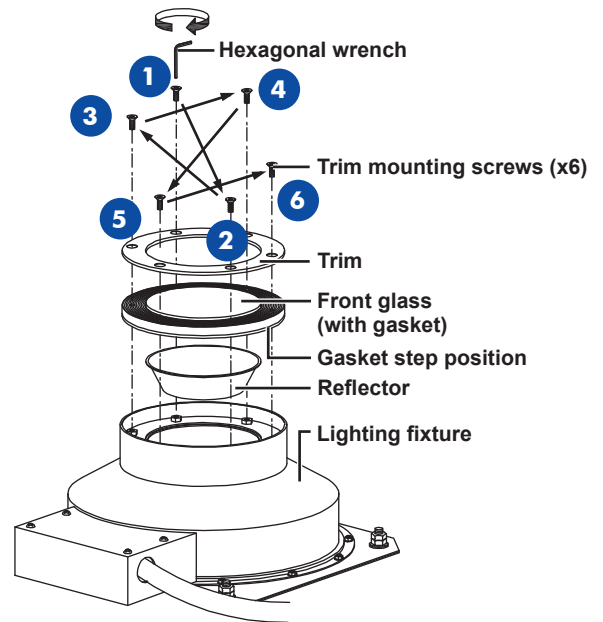

Warning

- Insufficient installation can impair the waterproof function and may cause insulation failure or electrical leakage.

11 Embed the fixture.

< LLG-7133 >

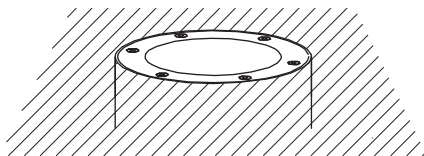

< LLG-7134 >

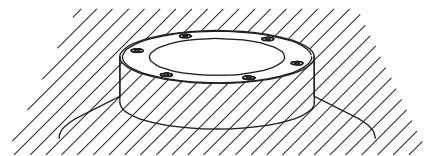

12 Installation of optional accessories

● Wide diffusion lens

Model No.	Wide diffusion lens
LLG-7133	LZA-92557
LLG-7134	LZA-92558

Spread lens

Model No.	Spread lens
LLG-7133	LZA-90571
LLG-7134	LZA-90435

Face the uneven side of the lens toward the lighting fixture and fit it into the lighting fixture.

● Flood lens

Model No.	Flood lens
LLG-7133	LZA-90572
LLG-7134	LZA-90635

Fit the lens or filter into the lighting fixture.

● Honeycomb louver

Model No.	Honeycomb louver
LLG-7133	LZA-92953
LLG-7134	LZA-92954

Fit the honeycomb louver into the lighting fixture.

As shown below, pinch the mounting spring knobs in the direction of the arrow and fit it into the lower mounting groove inside the lighting fixture.

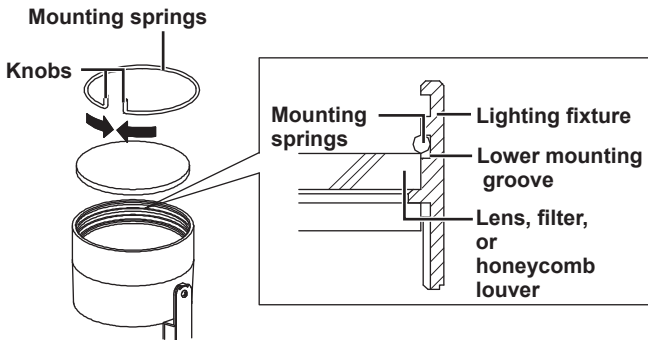

● When using a combination of two types of lenses or filters, or a honeycomb louver, stack two and fit them into the lighting fixture.

As shown below, pinch the mounting spring knobs in the direction of the arrow and fit it into the upper mounting groove inside the lighting fixture.

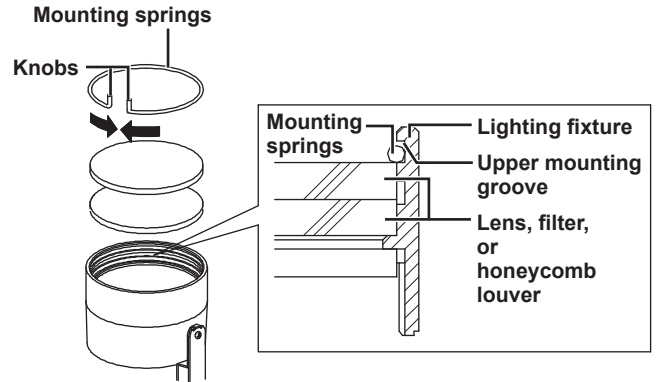

● Light shield plate (LLA-7135U)

Set the reflector on the lighting fixture, then place the light shield plate on top of the reflector with its opening facing the illumination direction side.

< LLG-7133 >

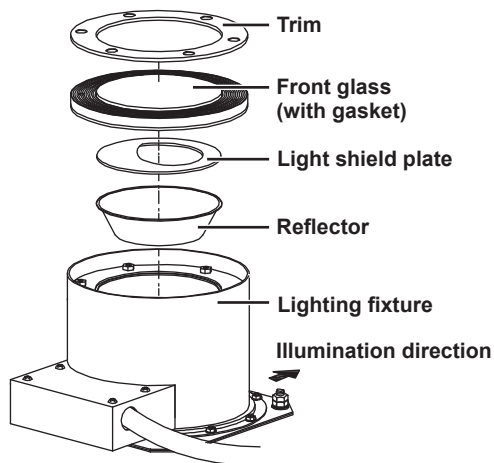

< LLG-7134 >

